

Features:

- Consists of 1 Clock lane and 2 Data lanes
- Complies with MIPI Standard 1.1 for D-PHY
- Supports both high speed and low-power modes
- 80 Mbps to 1.0Gbps data rate in high speed mode
- 20 Mbps data rate in low-power mode
- High Speed Deserializers included
- Low power dissipation

General Description:

The MXL-PHY-DSI-RX is a high-frequency low-power, low-cost, source-synchronous, Physical Layer compliant with the MIPI Alliance Standard for D-PHY.

The IP is configured as a MIPI slave and consists of 3 lanes: 1 Clock lane and 2 data lanes, which makes it suitable for Display Serial Interface applications (DSI).

The High-Speed signals have a low voltage swing while Low-Power signals have large swing. High-Speed functions are used for High-Speed Data traffic while low power functions are mostly used for control.

Block Diagram:

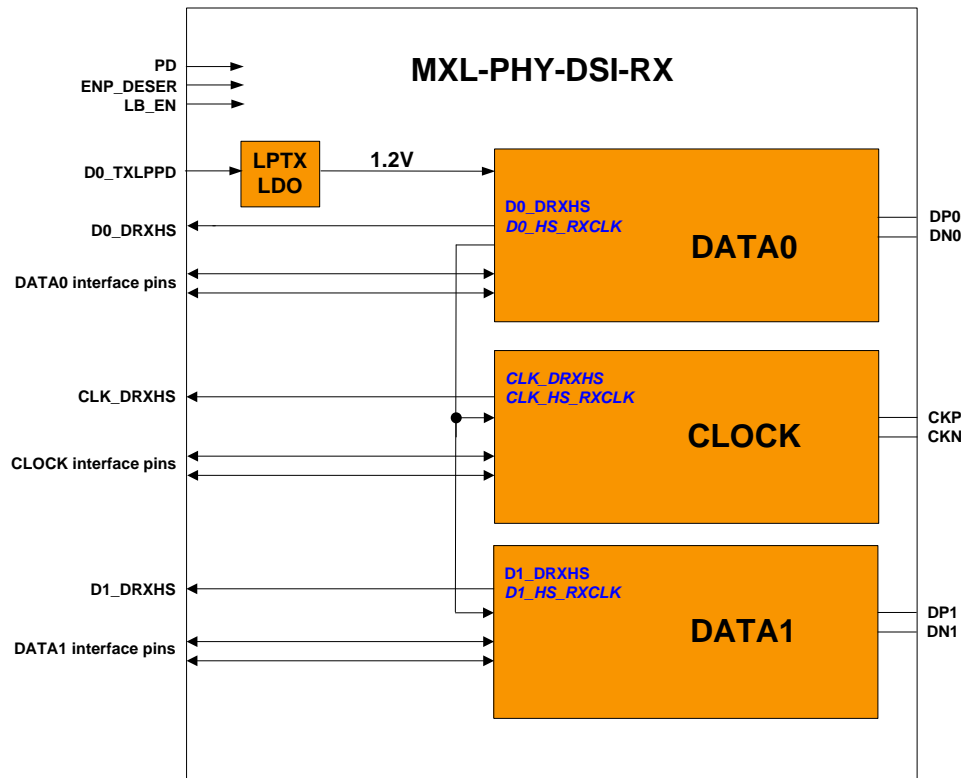

Figure 1 – PHY Block Diagram